



INSTRUCTION MANUAL

VHF DIGITAL TRANSCEIVERS

IC-F3230D Series

UHF DIGITAL TRANSCEIVERS

IC-F4230D Series

This device complies with Part 15 of the FCC Rules. Operation is subject to the condition that this device does not cause harmful interference.

Icom Inc.



The photo shows the VHF transceiver (S type)

IMPORTANT

READ ALL INSTRUCTIONS carefully and completely before using the transceiver.

SAVE THIS INSTRUCTION MANUAL — This instruction manual contains important operating instructions for the **IC-F3230DT, IC-F3230DS VHF DIGITAL TRANSCEIVERS** and the **IC-F4230DT, IC-F4230DS UHF DIGITAL TRANSCEIVERS**.

/// See the operating guide for details of IDAS (ICOM Digital Advanced System) system operations. Ask your dealer for details.

Icom, Icom Inc. and the Icom logo are registered trademarks of Icom Incorporated (Japan) in Japan, the United States, the United Kingdom, Germany, France, Spain, Russia, Australia, New Zealand, and/or other countries.

EXPLICIT DEFINITIONS

WORD	DEFINITION
⚠ DANGER!	Personal death, serious injury or an explosion may occur.
⚠ WARNING!	Personal injury, fire hazard or electric shock may occur.
CAUTION	Equipment damage may occur.
NOTE	If disregarded, inconvenience only. No risk of personal injury, fire or electric shock.

VOICE CODING TECHNOLOGY

The AMBE+2™ voice coding Technology embodied in this product is protected by intellectual property rights including patent rights, copyrights and trade secrets of Digital Voice Systems, Inc. This voice coding Technology is licensed solely for use within this Communications Equipment. The user of this Technology is explicitly prohibited from attempting to extract, remove, decompile, reverse engineer, or disassemble the Object Code, or in any other way convert the Object Code into a human-readable form. U.S. Patent Nos.

#5,870,405, #5,826,222, #5,754,974, #5,701,390, #5,715,365, #5,649,050, #5,630,011, #5,581,656, #5,517,511, #5,491,772, #5,247,579, #5,226,084 and #5,195,166.

PRECAUTIONS

⚠ DANGER! NEVER short terminals of the battery pack. Also, current may flow into nearby metal objects such as a key, so be careful when placing the battery packs (or the transceiver) in handbags, etc. Simply carrying with or placing near metal objects such as a key, etc. may cause shorting. This may damage not only the battery pack, but also the transceiver.

⚠ DANGER! Use and charge only specified Icom battery packs with Icom transceivers or Icom chargers. Only Icom battery packs are tested and approved for use with Icom transceivers or charged with Icom chargers. Using third-party or counterfeit battery packs or chargers may cause smoke, fire, or cause the battery to burst.

⚠ WARNING! NEVER hold the transceiver so that the antenna is very close to, or touching exposed parts of the body, especially the face or eyes, while transmitting. The transceiver will perform best if the microphone is 5 to 10 cm (2 to 4 inches) away from the lips and the transceiver is vertical.

⚠ WARNING! NEVER operate the transceiver with a headset or other audio accessories at high volume levels. The continuous high volume operation may cause a ringing in your ears. If you experience the ringing, reduce the volume level or discontinue use.

⚠ WARNING! NEVER operate the transceiver while driving a vehicle. Safe driving requires your full attention—anything less may result in an accident.

CAUTION: MAKE SURE the flexible antenna, battery pack and jack cover are securely attached to the transceiver, and that the antenna and battery pack are dry before attachment. Exposing the inside of the transceiver to dust or water will result in serious damage to the transceiver.

DO NOT operate the transceiver near unshielded electrical blasting caps or in an explosive atmosphere.

DO NOT push [PTT] when you do not actually intend to transmit.

DO NOT operate or place the transceiver in direct sunlight or in areas with temperatures below -30°C (-22°F) or above $+60^{\circ}\text{C}$ ($+140^{\circ}\text{F}$).

DO NOT modify the transceiver. The specifications may change and then not comply with the requirements of a corresponding regulation. The transceiver warranty does not cover any problems caused by unauthorized modification.

DO NOT use harsh solvents such as benzine or alcohol when cleaning, as they will damage the transceiver surfaces.

PRECAUTIONS (Continued)

BE CAREFUL! The transceiver will become hot when operating it continuously for long periods of time.

BE CAREFUL! The transceiver meet IP67* requirements for dust-tight and waterproof protection. However, once the transceiver has been dropped, dust-tight and waterproof protection cannot be guaranteed because of possible damage to the transceiver's case or the waterproof seal.

* Only when the jack cover or the optional HM-168LWP is attached.

Even when the transceiver power is OFF, a slight current still flows in the circuits. Remove the battery pack or batteries from the transceiver when not using it for a long time. Otherwise, the installed battery pack or batteries will become exhausted, and will need to be recharged or replaced.

MAKE SURE to turn OFF the transceiver power before connecting the supplied/optional equipment.

FCC INFORMATION

• **FOR CLASS A UNINTENTIONAL RADIATORS:**

This equipment has been tested and found to comply with the limits for a Class A digital device, pursuant to part 15 of the FCC Rules. These limits are designed to provide reasonable protection against harmful interference when the equipment is operated in a commercial environment. This equipment generates, uses, and can radiate radio frequency energy and, if not installed and used in accordance with the instruction manual, may cause harmful interference to radio communications. Operation of this equipment in a residential area is likely to cause harmful interference in which case the user will be required to correct the interference at his own expense.

CAUTION: Changes or modifications to this transceiver, not expressly approved by Icom Inc., could void your authority to operate this transceiver under FCC regulations.

TABLE OF CONTENTS

IMPORTANT	i	■ BP-240 optional battery case	17
EXPLICIT DEFINITIONS	i	■ BP-261 optional battery case	18
VOICE CODING TECHNOLOGY	i	6 SPEAKER MICROPHONE	20
PRECAUTIONS	ii	■ Optional HM-168LWP description	20
FCC INFORMATION	iii	■ Attaching	20
TABLE OF CONTENTS	iv	7 OPTIONAL SWIVEL BELT CLIP	21–22
1 ACCESSORIES	1–2	■ MB-93 contents	21
■ Supplied accessories	1	■ Attaching	21
■ Accessory attachments	1	■ Detaching	22
2 PANEL DESCRIPTION	3–7	8 OPTIONS	23–24
■ Front panel	3	9 SAFETY TRAINING INFORMATION	25–26
■ Function display	4		
■ Programmable function keys	5		
3 BASIC OPERATION	8–10		
■ Turning power ON	8		
■ Channel selection	9		
■ User set mode	9		
■ Priority A channel selection	9		
■ Receiving and transmitting	10		
4 BATTERY CHARGING	11–16		
■ Caution	11		
■ Battery chargers	13		
5 BATTERY CASE	17–19		

■ Supplied accessories

/// **NOTE:** Some accessories are not supplied, depending on the transceiver version.

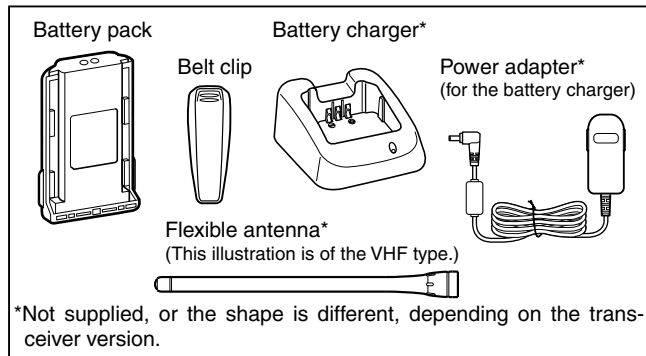

■ Accessory attachments

◇ Flexible antenna

Connect the supplied flexible antenna to the antenna connector.

/// CAUTION:

- **NEVER** carry the transceiver by holding only the antenna.
- **DO NOT** connect an antenna other than those listed on page 24.
- Transmitting without an antenna may damage the transceiver.

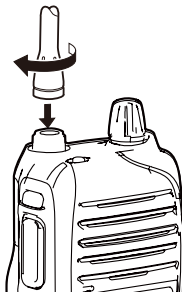

◇ Battery pack

To attach the battery pack:

Slide the battery pack in the direction of the arrow (①) until the battery release button makes a 'click' sound.

/// **NOTE:** Push on the bottom of the pack to make sure the release button is firmly locked.

To release the battery pack:

Slide the battery release button in the direction of the arrow (②) as shown below. The battery pack is then released.

/// **NEVER** release or attach the battery pack when the transceiver is wet or soiled. This may result water or dust getting into the transceiver/battery pack and may result in the transceiver being damaged.

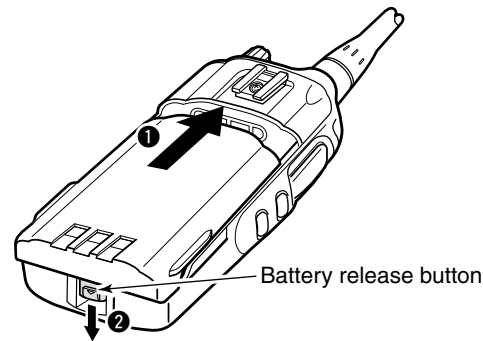

/// **NOTE:** Keep battery terminals clean. It's a good idea to occasionally clean them.

◇ Belt clip

To attach the belt clip:

- ① Remove the battery pack if it is attached.
- ② Slide the belt clip in the direction of the arrow until the belt clip is locked and makes a 'click' sound.

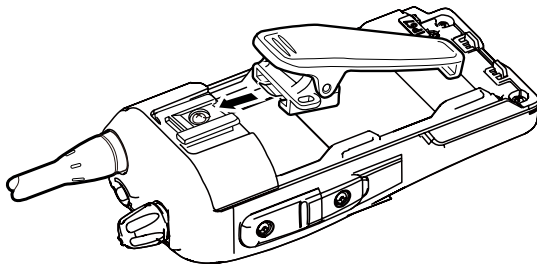

To detach the belt clip:

- ① Remove the battery pack if it is attached.
- ② Pinch the clip (1), and slide the belt clip in the direction of the arrow (2).

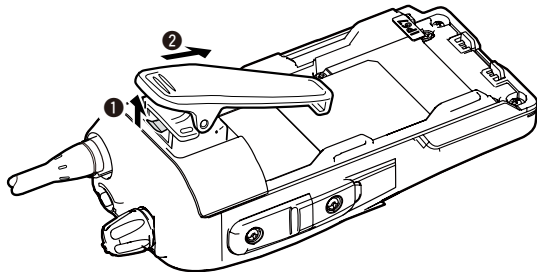

◇ Jack cover

To attach the jack cover:

- ① Attach the jack cover to the [MIC/SP] jack. (1)
- ② Tighten the screws. (2)

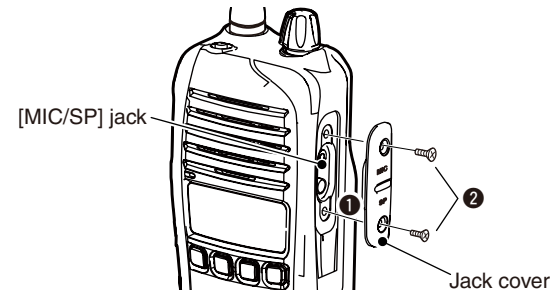

CAUTION:

- Attach the jack cover when the optional equipment is not used.
- Use only the supplied screws.

To detach the jack cover:

- ① Unscrew the screws using a phillips screwdriver. (1)
- ② Detach the jack cover to connect the optional equipment. (2)

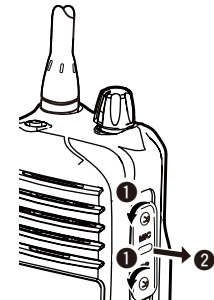

■ Front panel

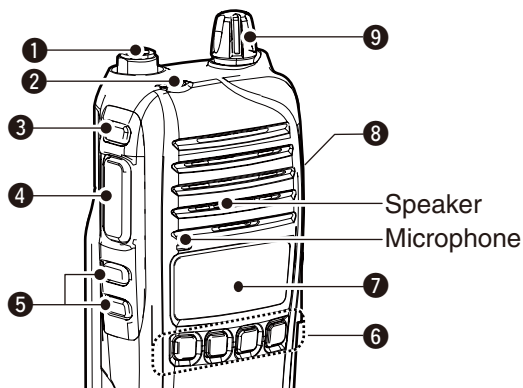

1 ANTENNA CONNECTOR

Connects the supplied antenna.

2 DEALER-PROGRAMMABLE KEY [Emer]

A desired function can be programmed by your dealer. (p. 5)

3 DEALER-PROGRAMMABLE KEY [Side1]

A desired function can be programmed by your dealer. (p. 5)

4 PTT SWITCH [PTT]

Hold down to transmit, release to receive.

5 DEALER-PROGRAMMABLE KEYS [Side2]/[Side3]

Desired functions can be independently programmed by your dealer. (p. 5)

6 DEALER-PROGRAMMABLE KEYS [P0] to [P3]

Desired functions can be independently programmed by your dealer. (p. 5)

7 FUNCTION DISPLAY (p. 4)

Displays a variety of information such as an operating channel number, channel name, User Set mode contents, and so on.

8 EXTERNAL MICROPHONE/SPEAKER JACK

Connect an optional equipment.

NOTE: Connect or disconnect the optional equipment after the transceiver is turned OFF.

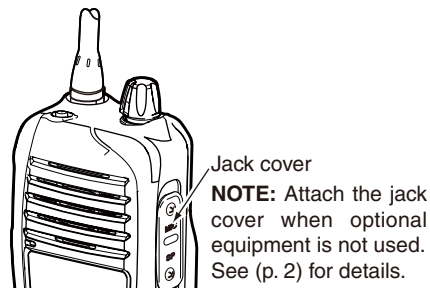

9 VOLUME CONTROL [VOL]

Rotate to turn the power ON or OFF and to adjust the audio level.

■ Function display

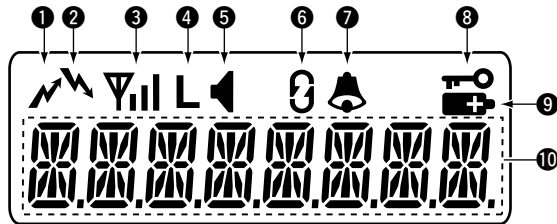

1 TRANSMIT ICON

Appears while transmitting.

2 BUSY ICON

Appears while the channel is busy (receiving).

3 SIGNAL STRENGTH ICON

Shows the relative receive signal strength level.



Weak ⇐ Receive Signal level ⇒ Strong

About “▽” icon for the Trunking mode

- Disappears while in a no service area.
- Blinks while registering to a repeater.
- Appears when registration is completed.

4 LOW POWER ICON

Appears when low output power is selected.

- When the battery power decreases to a specified level, low power is automatically selected.

5 AUDIBLE ICON

- In the analog mode, appears when the CTCSS (DTCS) squelch mute is released while holding down [Monitor].
- In the digital mode, appears while holding down [Monitor].

6 ENCRYPTION ICON

In the digital mode, appears when the encryption function is activated.

7 BELL ICON

In the digital mode, appears/blinks when an SDM (Short Data Message), Status Call or Call Alert is received, depending on the preprogramming.

8 KEY LOCK ICON

Appears when the Key lock function is ON.

9 BATTERY ICON

Appears or blinks when the battery power decreases to a specified level.

10 ALPHANUMERIC DISPLAY

Displays an operating channel number, channel name, User Set mode contents, and so on.

2 PANEL DESCRIPTION

■ Programmable function keys

The following functions can be assigned to **[Emer]**, **[Side1]**, **[Side2]**, **[Side3]**, **[P0]**, **[P1]**, **[P2]** and **[P3]** programmable function keys.

Consult your Icom dealer or system operator for details concerning your transceiver's programming.

CH UP AND DOWN

As described in the following topics, after pushing a programmed key, push **[CH Up]** or **[CH Down]** to select an option, setting, and so on.

ZONE

Push this key, then select the desired zone using **[CH Up]**/**[CH Down]**.

 **What is a “zone”?**— Certain channels are grouped together and assigned to a zone, according to their intended use. For example, ‘Staff A’ and ‘Staff B’ are assigned to a “Business” zone, and ‘John’ and ‘Cindy’ are assigned to a “Private” zone.

SCAN START/STOP

- Push to start and cancel a scan.
 - When a scan is started with the Power ON Scan or Automatic scan function, push this key to cancel it. The cancelled scan resumes after a preprogrammed time period.
- Hold down this key for 1 second to display the scan group, then push **[CH Up]** or **[CH Down]** to select the desired group.

SCAN ADD/DEL (TAG)

- Push to add the channel to, or delete it from, the current scan group.
 1. Push to display the scan group, then push **[CH Up]** or **[CH Down]** to select the desired one.
 2. Push to add the channel to, or delete it from, the selected scan group.
 3. Hold down for 1 second to exit the scan list selection mode.
- While a scan is paused on a non-priority channel, push this key to delete the selected channel from the scan group.

 Depending on the setting, the cleared channel may be automatically added to the scan group again after the scan is cancelled.

PRIORITY A CHANNEL, PRIORITY B CHANNEL

Push to select the Priority A or Priority B channel.

PRIORITY A CHANNEL (REWRITE),**PRIORITY B CHANNEL (REWRITE)**

- Push to select the Priority A or Priority B channel.
- Hold down [Prio A (Rewrite)] or [Prio B (Rewrite)] for 1 second to assign the operating channel to Priority A or Priority B channel, respectively.

MEMORY CHANNELS 1, 2, 3, 4

Push to directly select memory channel 1, 2, 3 or 4, if programmed.

Consult your dealer for details.

MONITOR

Push to turn the CTCSS (DTCS) squelch mute ON or OFF.

LIGHT

Push to turn ON the backlight for about 5 seconds, when the backlight function is set to "OFF" in the User Set mode.

LOCK

- Hold down this key until "LOCK ON" is displayed to electronically lock all programmable keys except the following: [Moni], [Lock], [Emergency]*, [Surveillance], [Siren], [Lone Worker]*, [Light] and [Shift].
*For digital operation. See the operating guide for details
- To turn OFF the Key Lock function, hold down this key until "LOCK OFF" is displayed.

HIGH/LOW

Push to select the transmit output power temporarily or permanently, depending on the preprogramming.

- Ask your dealer for the output power level for each selection.

TALK AROUND

Push to turn the Talk Around function ON or OFF.

- The Talk Around function equalizes the transmit frequency to the receive frequency for transceiver-to-transceiver communication.

WIDE/NARROW

Push to toggle the IF bandwidth between wide and narrow.

SURVEILLANCE

Push to turn the surveillance function ON or OFF.

When this function is turned ON and a signal is received, the beep is not heard and the LED does not light, even if a key is pushed.

2 PANEL DESCRIPTION

■ Programmable function keys (Continued)

SIREN

Hold down for 1 second to sound the siren.

This function can be used for situations other than an emergency alert, such as a security alarm for example.

- The siren can be stopped only by turning OFF the transceiver power.

USER SET MODE

➔ Hold down for 1 second to enter the User Set mode.

- While in the User Set mode, push this key to select an item*, and change the value or setting by pushing [CH Up] or [CH Down].

*Selectable items may differ, depending on the preprogramming.

➔ Hold down this key for 1 second again to exit the User Set mode.

ANNOUNCE

Push to turn the Channel Announce function ON or OFF.

When this function is turned ON, the transceiver announces the channel number when it is selected.

RESET

➔ Push to return to the normal operating mode.

➔ While in the audible mode, push to return to the inaudible mode.

 **NOTE:** See the operating guide for the [Reset] key operation in the digital mode.

SHIFT

Push to toggle the Normal mode key functions and the Shift mode key functions.

- When the Shift mode is selected, the display briefly shows “SHIFT ON.” When the Normal mode is selected, the display briefly shows “SHIFT OFF.”

■ Turning power ON

/// Prior to using the transceiver for the first time, the battery pack must be fully charged for optimum life and operation. (p. 12)

- ① Rotate [VOL] to turn ON the power.
- ② If the transceiver is programmed for a start up password, input the digit codes as directed by your dealer.
 - The 10-keypad may be used for password input, depending on the transceiver's version:
 - The keys in the table below can be used for password input.
 - The transceiver detects numbers in the same block as identical. Therefore "01234" and "56789" are the same.

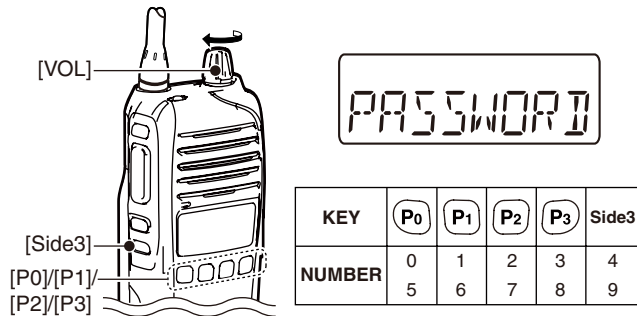

- ③ When the "PASSWORD" indication does not clear after inputting 4 digits, the input code number may be incorrect. Turn the power off and start over in this case.

◇ Battery type selection

The battery type must be selected according to the attached battery type when turning ON the transceiver. Ask your dealer for details.

- ① Turn OFF the power.
- ② While pushing and holding [Emer] and [PTT], turn ON the power by rotating [VOL] to toggle the attached battery type.
 - After the display appears, release [Emer] and [PTT].
 - "DRY BATT" is displayed for about 3 seconds then "L" appears when the battery case use is selected. In this case, the transmit output power is low.
 - "LI-ION" is displayed for about 3 seconds when the Lithium-ion battery use is selected.

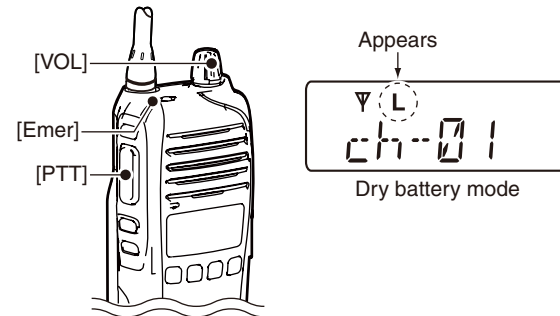

3 BASIC OPERATION

■ Channel selection

Several types of channel selections are available. Methods may differ, depending on your system set up.

NON-ZONE TYPE:

To select the desired operating channel:

- ➔ Push [CH Up] or [CH Down].
- ➔ Push one of [MR-CH 1] to [MR-CH 4].
- ➔ Push one of these keys, [Prio A], [Prio B], [Prio A (Rewrite)] or [Prio B (Rewrite)].

ZONE TYPE:

To select the desired operating channel:

- ➔ Push [Zone], then push [CH Up] or [CH Down].

VOTING OPERATION:

The transceiver automatically starts scanning when a zone, specified for the voting operation, is selected.

The voting scan detects the S-meter of the repeater and automatically selects the strongest station.

AUTOMATIC SCAN TYPE:

Channel setting is not necessary for this type. When turning ON the power, the transceiver automatically starts scanning. Scanning stops when a signal is received.

■ User set mode

The User Set mode allows you to set seldom-changed settings. If the transceiver has [User Set Mode] assigned to it, you can “customize” the transceiver operation to suit your preferences and operating style.

Entering the User Set mode:

- ① Hold down [User Set Mode] for 1 second to enter the User Set mode.
- ② Push [User Set Mode] several times to select the appropriate item. Then push [CH Up] or [CH Down] to set the desired level or condition.
 - Selectable Set mode items are Backlight, Beep ON/OFF, Beep Level, Ringer Level, SQL Level, AF Min Level, Mic Gain, Battery Voltage, Signal Moni, Lone Worker and System Info.
- ③ Hold down [User Set Mode] for 1 second again to exit the User Set mode.

■ Priority A channel selection

When one of the following operations is performed, the transceiver automatically selects Priority A channel.

- **Turning ON the power**
Priority A channel is selected each time the transceiver's power is turned ON.
- **Auto Reset**
Priority A channel is selected when the Auto Reset timer ends.
- **OFF hook**
Priority A channel is selected when you take the microphone OFF hook.

■ Receiving and transmitting

CAUTION: Transmitting without an antenna may damage the transceiver. See page 1 for accessory attachments.

Receiving:

- ① Rotate [VOL] to turn ON the power.
- ② Push [CH Up] or [CH Down] to sequentially select the conventional system channel.
- ③ When receiving a call, adjust the audio output level to a comfortable listening level.

Transmitting:

Wait for the channel to become clear to avoid interference.

- ① While pushing and holding [PTT], speak into the microphone at a normal voice level.
- ② Release [PTT] to return to receive.

IMPORTANT: To maximize the readability of your signal;

1. Pause briefly after pushing [PTT].
2. Hold the microphone 5 to 10 cm (2 to 4 inches) from your mouth, then speak at a normal voice level.

◇ **Transmitting notes**

• **Transmit inhibit function**

The transceiver has several inhibit functions which restrict transmission under the following conditions:

- The channel is busy. However, depending on the pre-programmed settings, you can transmit when the call includes an unmatching (or matching) CTCSS (DTCS), RAN code*, or Individual or Talkgroup ID*.
- * Digital operation only
- The selected channel is a 'receive only' channel.

• **Time-out timer**

If continuous transmission exceeds the preprogrammed time-out timer limit, the transmission is cut off.

• **Penalty timer**

After the transmission is cut off by the time-out timer, transmission is further inhibited for the preprogrammed penalty timer period.

■ Caution

- Misuse of Lithium-ion batteries may result in the following hazards: smoke, fire, or the battery may rupture. Misuse can also cause damage to the battery or degradation of battery performance.
- Prior to using the battery pack for the first time, or after not using it for a long time, you must fully charge the pack. Otherwise, the transceiver may not turn ON.

◇ Battery caution

⚠ **DANGER! DO NOT** hammer or otherwise impact the battery. Do not use the battery if it has been severely impacted or dropped, or if the battery has been subjected to heavy pressure. Battery damage may not be visible on the outside of the case. Even if the surface of the battery does not show cracks or any other damage, the cells inside the battery may rupture or catch fire.

⚠ **DANGER! NEVER** use or leave battery packs in areas with temperatures above +60°C (+140°F). High temperature build-up in the battery, such as could occur near fires or stoves, inside a sun heated car, or in direct sunlight may cause the battery to rupture or catch fire. Excessive temperatures may also degrade battery performance or shorten battery life.

⚠ **DANGER! DO NOT** expose the battery to rain, snow, seawater, or any other liquids. Never charge or use a wet battery. If the battery gets wet, be sure to wipe it dry before using.

⚠ **DANGER! NEVER** incinerate used battery packs since internal battery gas may cause them to rupture, or may cause an explosion.

⚠ **DANGER! NEVER** solder the battery terminals or NEVER modify the battery pack. This may cause heat generation, and the battery may rupture, emit smoke or catch fire.

⚠ **DANGER!** Use the battery only with the transceiver for which it is specified. Never use a battery with any other equipment, or for any purpose that is not specified in this instruction manual.

⚠ **DANGER!** If fluid from inside the battery gets in your eyes, blindness can result. Rinse your eyes with clean water, without rubbing them, and see a doctor immediately.

⚠ **WARNING!** Immediately stop using the battery if it emits an abnormal odor, heats up, or is discolored or deformed. If any of these conditions occur, contact your Icom dealer or distributor.

⚠ **WARNING!** Immediately wash, using clean water, any part of the body that comes into contact with fluid from inside the battery.

⚠ **WARNING! NEVER** put the battery in a microwave oven, high-pressure container, or in an induction heating cooker. This could cause a fire, overheating, or cause the battery to rupture.

CAUTION: Always use the battery within the specified temperature range, -20°C to $+60^{\circ}\text{C}$ (-4°F to $+140^{\circ}\text{F}$). Using the battery out of its specified temperature range will reduce the battery's performance and battery life.

CAUTION: Shorter battery life could occur if the battery is left fully charged, completely discharged, or in an excessive temperature environment (above $+50^{\circ}\text{C}$; $+122^{\circ}\text{F}$) for an extended period of time. If the battery must be left unused for a long time, it must be detached from the transceiver after discharging. You may use the battery until the remaining capacity is about half, then keep it safely in a cool dry place with the temperature range as below:

- -20°C to $+50^{\circ}\text{C}$ (-4°F to $+122^{\circ}\text{F}$) (within a month)
- -20°C to $+35^{\circ}\text{C}$ (-4°F to $+95^{\circ}\text{F}$) (within three months)

BE SURE to replace the battery pack with a new one approximately five years after purchasing, even if it still holds a charge. The inside battery material will become weak after a period of time, even with little use. The estimated number of charging and discharging cycles is between 300 and 500, depending on the type of operation. Even when the battery appears to be fully charged, the operating time of the transceiver may become short when:

- Approximately five years have passed since the battery was manufactured.
- The battery has been repeatedly charged.

◇ Charging caution

⚠ **DANGER! NEVER** charge the battery pack in areas with extremely high temperatures, such as near fires or stoves, inside a sun heated car, or in direct sunlight. In such environments, the safety/protection circuit in the battery will activate, causing the battery to stop charging.

⚠ **WARNING! NEVER** charge or leave the battery in the battery charger beyond the specified time for charging. If the battery is not completely charged by the specified time, stop charging and remove the battery from the battery charger. Continuing to charge the battery beyond the specified time limit may cause a fire, overheating, or the battery may rupture.

⚠ **WARNING! NEVER** insert the transceiver (battery attached to the transceiver) into the charger if it is wet or soiled. This could corrode the battery charger terminals or damage the charger. The charger is not waterproof.

CAUTION: NEVER charge the battery outside of the specified temperature range: BC-160/BC-171 (0°C to $+45^{\circ}\text{C}$; $+32^{\circ}\text{F}$ to $+113^{\circ}\text{F}$). BC-119N/BC-121N/BC-197 ($+10^{\circ}\text{C}$ to $+40^{\circ}\text{C}$; $+50^{\circ}\text{F}$ to $+104^{\circ}\text{F}$). Icom recommends charging the battery at $+20^{\circ}\text{C}$ ($+68^{\circ}\text{F}$). The battery may heat up or rupture if charged out of the specified temperature range. Additionally, battery performance or battery life may be reduced.

4 BATTERY CHARGING

■ Battery chargers

◇ Rapid charging with the BC-160

The optional BC-160 rapidly charges the Li-ion battery pack.

- A power adapter (may be supplied with BC-160, depending on the version) or the DC power cable (OPC-515L/CP-23L) is additionally required.

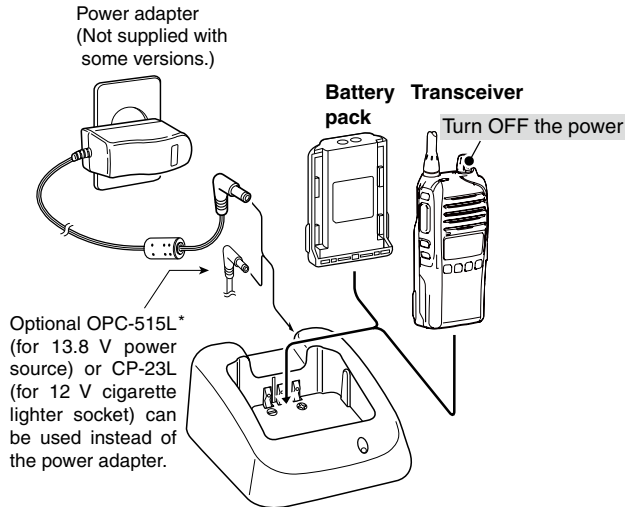

/// ***CAUTION: NEVER** reverse the cable polarity when connecting the OPC-515L to a power source. This will ruin the battery charger.
/// White line: ⊕ Black line: ⊖

◇ Regular charging with the BC-171

The optional BC-171 regularly charges the Li-ion battery pack.

- A power adapter (may be supplied with BC-171, depending on the version) or the DC power cable (OPC-515L/CP-23L) is additionally required.

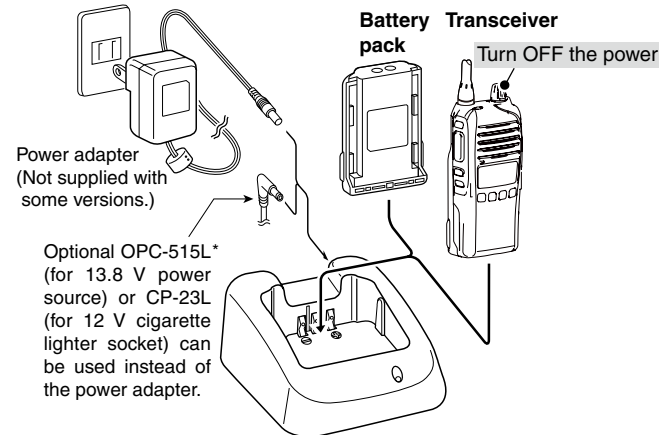

/// ***CAUTION: NEVER** reverse the cable polarity when connecting the OPC-515L to a power source. This will ruin the battery charger.
/// White line: ⊕ Black line: ⊖

◇ **AD-106 installation**

The AD-106 CHARGER ADAPTER must be installed into the BC-119N or BC-121N before battery charging.

- Connect the AD-106 CHARGER ADAPTER and the BC-119N/BC-121N as shown below, then install the AD-106 into the holder space of the BC-119N or BC-121N with the supplied screws.

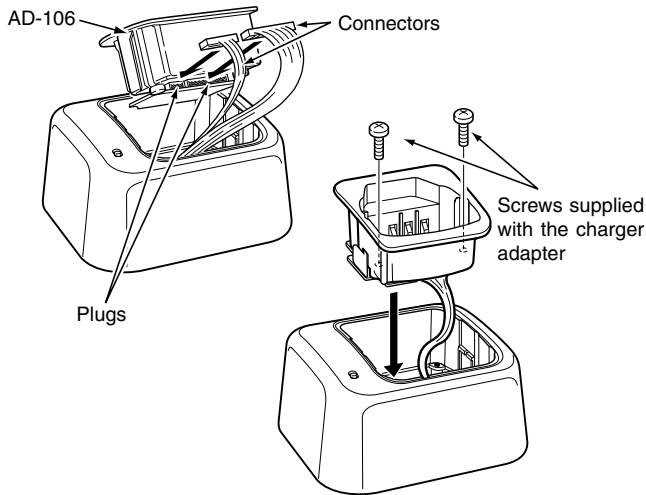

* This illustration is of the BC-119N.

◇ **Rapid charging with the BC-119N+AD-106**

The optional BC-119N rapidly charges the Li-ion battery pack. The following items are additionally required.

- AD-106 charger adapter
- A power adapter (may be supplied with the BC-119N, depending on the version) or the DC power cable (OPC-515L/CP-23L).

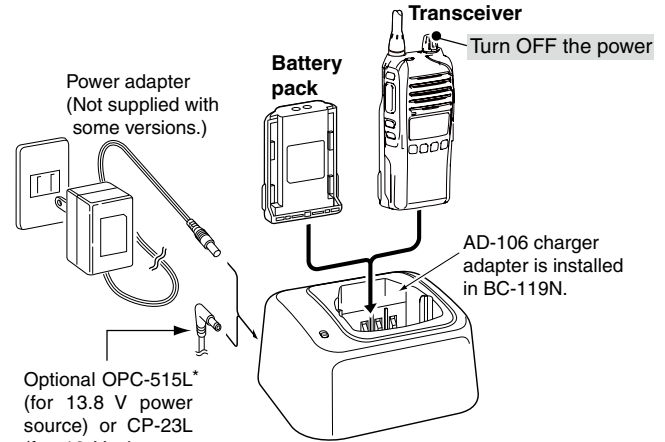

Optional OPC-515L* (for 13.8 V power source) or CP-23L (for 12 V cigarette lighter socket) can be used instead of the power adapter.

⚡ ***CAUTION: NEVER** reverse the cable polarity when connecting the OPC-515L to a power source. This will ruin the battery charger.
 ⚡ White line: ⊕ Black line: ⊖

4 BATTERY CHARGING

◇ Rapid charging with the BC-121N+AD-106

The optional BC-121N can simultaneously charge up to 6 Li-ion battery packs. The following items are additionally required.

- Six AD-106 charger adapters
- An optional power adapter or the DC power cable (OPC-656)

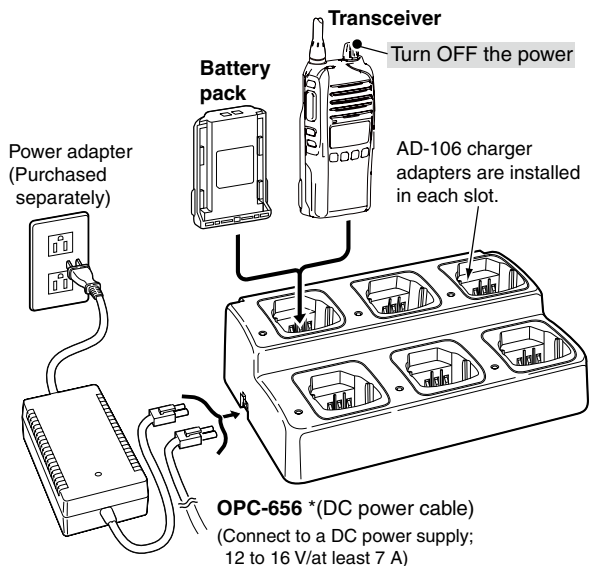

▨ ***CAUTION: NEVER** reverse the cable polarity when connecting the OPC-656 to a power source. This will ruin the battery charger.
▨ Red line: ⊕ Black line: ⊖

◇ Rapid charging with the BC-197

The optional BC-197 can simultaneously charge up to 6 Li-ion battery packs. The following items are additionally required.

- An optional power adapter (not supplied with some versions) or the DC power cable (OPC-656)

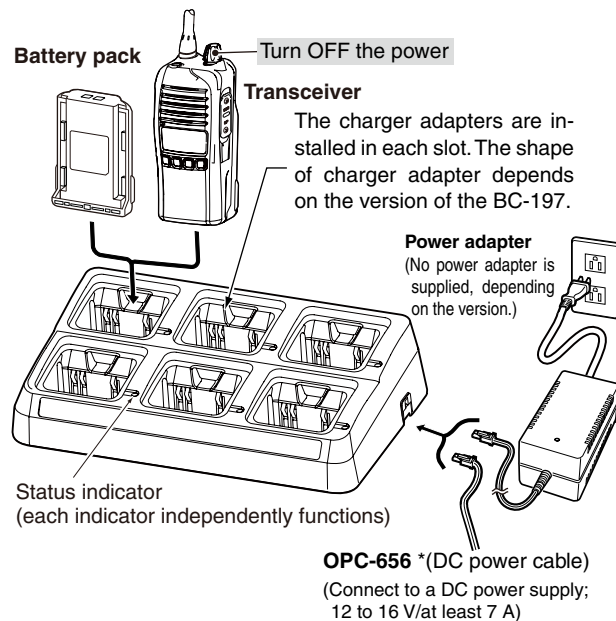

▨ ***CAUTION: NEVER** reverse the cable polarity when connecting the OPC-656 to a power source. This will ruin the battery charger.
▨ Red line: ⊕ Black line: ⊖

IMPORTANT: Battery charging caution

Ensure the guide tabs on the battery pack are correctly aligned with the guide rails inside the charger adapter.
(This illustration is of the BC-160.)

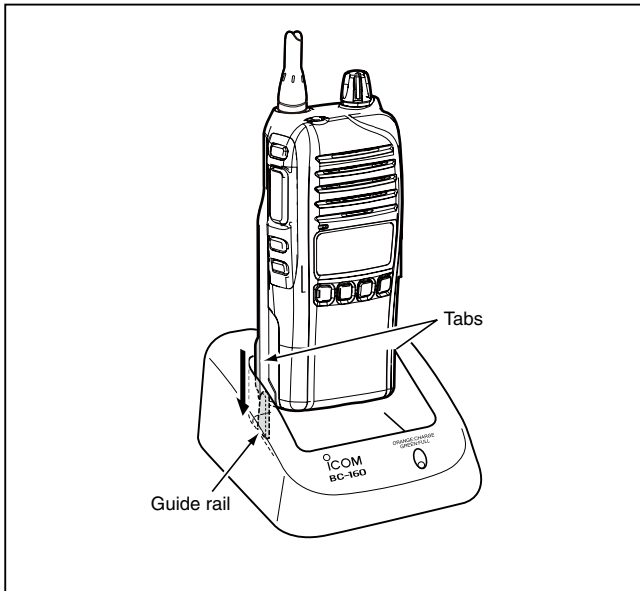

■ BP-240 optional battery case

When using the BP-240 battery case, install six AAA (LR03) size alkaline batteries, as illustrated to the right. The BP-240 is constructed to the IPX4 waterproof standard.

- ① Unhook the battery cover release hook (①), and open the cover in the direction of the arrow (②). (Fig.1)
- ② Install six AAA (LR03) size alkaline batteries. (Fig.2)
 - Install only alkaline batteries.
 - Be sure to observe the correct polarity.
- ③ Replace the cover in the direction of the arrow (③), then close (④). Push the battery cover release hook until it makes a 'click' sound (⑤). (Fig.3)

CAUTION:

- When installing the batteries, make sure they are all the same brand, type and capacity. Also, do not mix new and old batteries together.
- Keep battery terminals clean. It's a good idea to occasionally clean them.
- Never incinerate used battery cells since internal battery gas may cause them to rupture.
- Never expose a detached battery case to water. If the battery case gets wet, be sure to wipe it dry before using it.

NOTE: When the optional battery case is attached, the battery type must be set to "DRY BATT" when turning ON the transceiver. (p. 8)

Fig.1

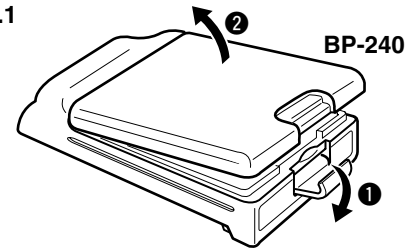

Fig.2

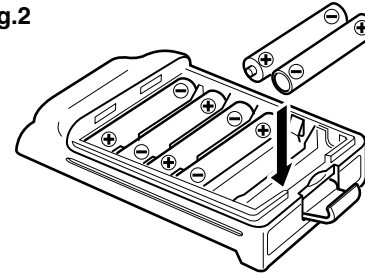
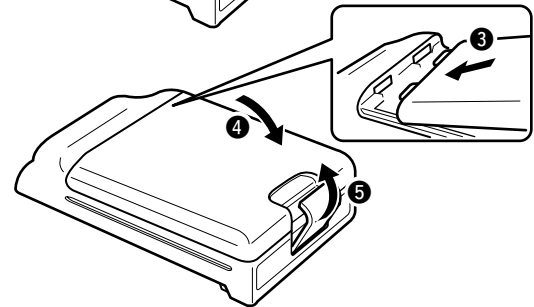

Fig.3



■ BP-261 optional battery case

◇ Alkaline batteries installation

Install six AA (LR6) size alkaline batteries as described below. The BP-261 is constructed to the IPX4 waterproof standard.

- ① Unhook the battery cover release hook (❶), and open the cover in the direction of the arrow (❷). (Fig.1)
- ② Install six AA (LR6) size alkaline batteries. (Fig.2)
 - Install only alkaline batteries.
 - Be sure to observe the correct polarity.
- ③ Replace the cover in the direction of the arrow (❸), then close (❹). Push the battery cover release hook until it makes a 'click' sound (❺). (Fig.3)

CAUTION:

- When installing the batteries, make sure they are all the same brand, type and capacity. Also, do not mix new and old batteries together.
- Keep battery terminals clean. It's a good idea to occasionally clean them.
- Never incinerate used battery cells since internal battery gas may cause them to rupture.
- Never expose a detached battery case to water. If the battery case gets wet, be sure to wipe it dry before using it.

NOTE: When the optional battery case is attached, the battery type must be set to "DRY BATT" when turning ON the transceiver. (p. 8)

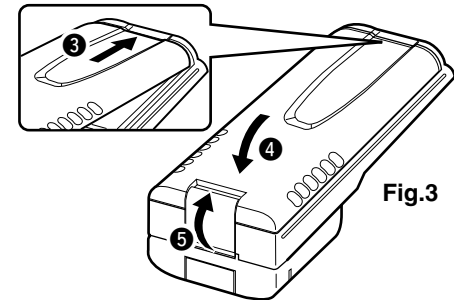
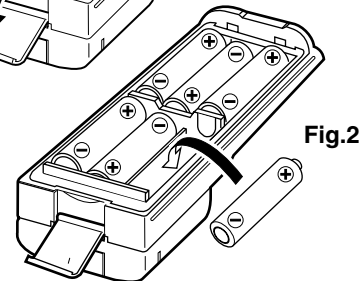
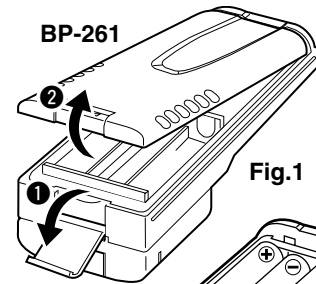

5 BATTERY CASE

■ BP-261 optional battery case (Continued)

◇ Attaching

Slide the battery pack in the direction of the arrow until the battery release button makes a 'click' sound.

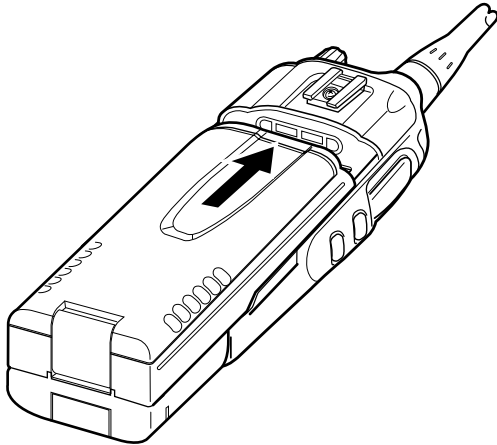

◇ Detaching

Slide the battery case's battery release button in the direction of the arrow (1), and then push the release button in the direction of the arrow (2). The battery pack is then released.

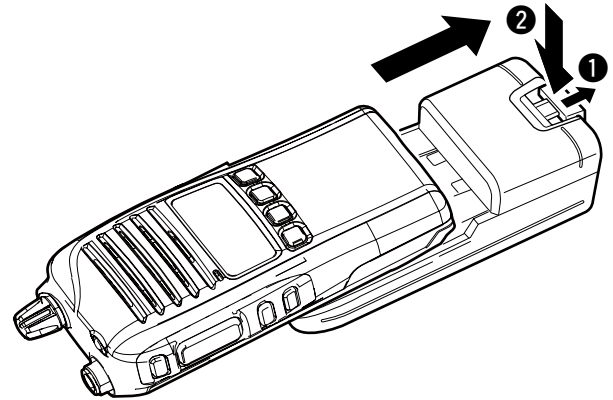

NEVER release or attach the battery case when the transceiver is wet or soiled. This may result water or dust getting into the transceiver or battery case and may result in the transceiver being damaged.

Optional HM-168LWP description

Alligator type clip

To attach the speaker-mic. to your shirt or collar, etc.

PTT switch

Transmits while pushed
Receives while released

Microphone

Speaker

Turn the transceiver power OFF when connecting the HM-168LWP.

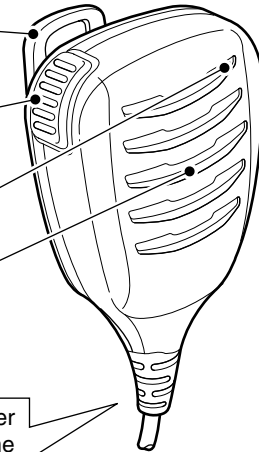

NEVER immerse the connector in water. If the connector becomes wet, be sure to dry it **BEFORE** attaching it to the transceiver.

NOTE: The microphone is located as shown in the diagram above. To maximize the readability of your transmitted signal (voice), hold the microphone approximately 5 to 10 cm (2 to 4 inches) from your mouth, and speak in a normal voice level.

Attaching

Attach the connector of the speaker-microphone into the [SP MIC] jack on the transceiver and tighten the screws with your fingers.

NOTE: Use only your fingers instead of tools to tighten the screws.

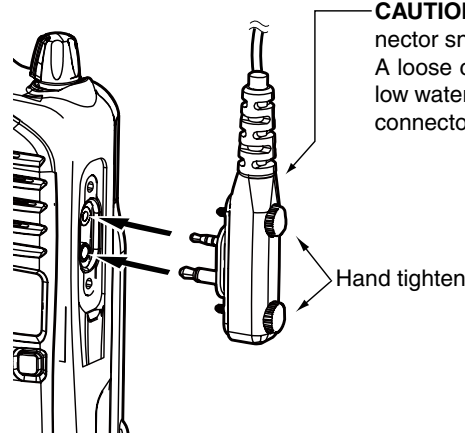

IMPORTANT: Keep the [SP MIC] jack cover attached to the transceiver when the speaker-microphone is not in use.

■ MB-93 contents

	Qty.
① Belt clip	1
② Base clip	1

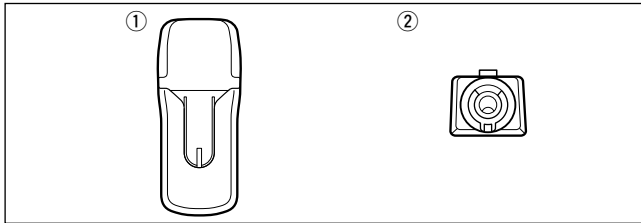

■ Attaching

- ① Release the battery pack if it is attached. (p. 1)
- ② Slide the base clip in the direction of the arrow until the base clip locks and makes a 'click' sound.

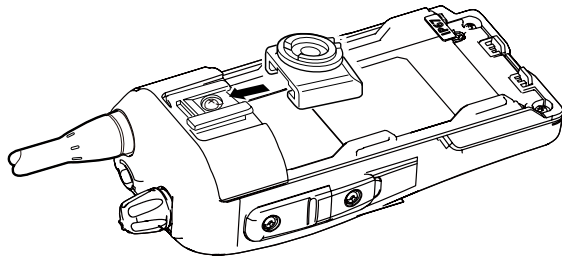

- ③ Attach the battery pack. (p. 1)

- ④ Clip the belt clip to a part of your belt. And insert the transceiver into the belt clip until the base clip inserted fully into the groove.

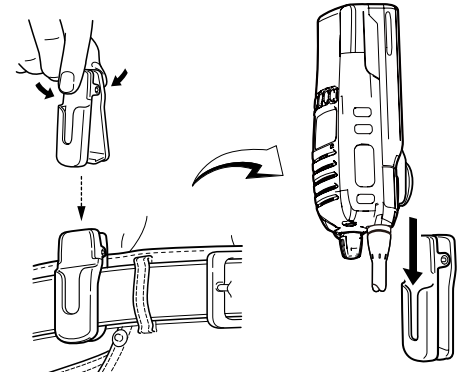

- ⑤ Once the transceiver is locked in place, it swivels as illustrated below.

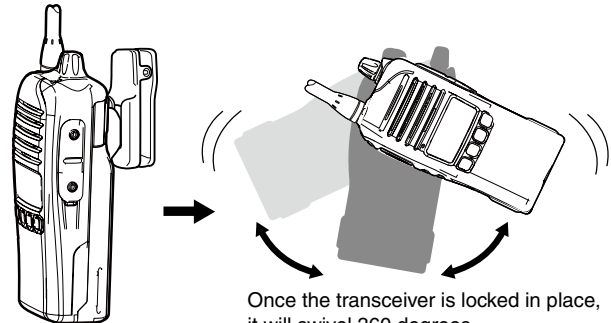

Once the transceiver is locked in place, it will swivel 360 degrees.

■ Detaching

- ① Turn the transceiver upside down in the direction of the arrow and pull it out of the belt clip.

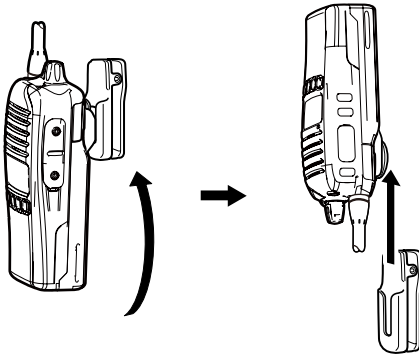

- ② Release the battery pack if it is attached. (p. 1)
- ③ Pinch the clip (①), and slide the base clip in the direction of the arrow (②).

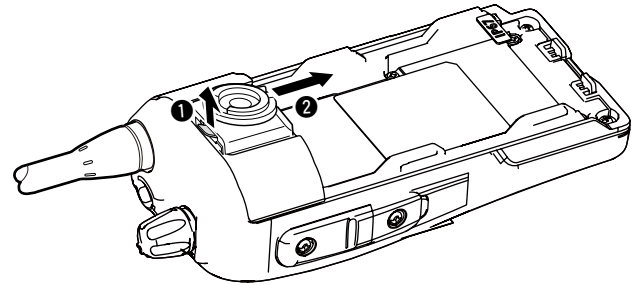

CAUTION:
HOLD THE TRANSCEIVER TIGHTLY, WHEN HANGING OR DETACHING THE TRANSCEIVER FROM THE BELT CLIP.
 Otherwise the transceiver may not be attached to the holder or swivel properly if the transceiver is accidentally dropped and the base clip is scratched or damaged.

◇ BATTERY PACK

Battery pack	Voltage	Capacity	Battery life*	
BP-232WP	7.4 V	2250 mAh (min.)	VHF	19 hrs.
		2300 mAh (typ.)	UHF	17 hrs.

*When the power save function is turned ON, and the operating periods are calculated under the following ratio;

TX : RX : standby = 5 : 5 : 90

• BP-240/BP-261 BATTERY CASE

BP-240: Battery case for 6 AAA (LR03) alkaline batteries

BP-261: Battery case for 6 AA (LR6) alkaline batteries

BP-240 and BP-261 have IPX4 waterproof protection. When in use, the transceiver's waterproof rating meets IPX4.

Operating period depends on the alkaline cells used.

◇ CHARGERS

• BC-119N DESKTOP CHARGER + AD-106 CHARGER ADAPTER + BC-145S AC ADAPTER

For rapid charging of battery packs. A power adapter may be supplied with the charger, depending on the versions.

Charging time: Approximately 3.5 hours for the BP-232WP.

• BC-121N MULTI-CHARGER + AD-106 CHARGER ADAPTER (6 pcs.) + BC-157S AC ADAPTER

For rapid charging of up to 6 battery packs (six AD-106's are required) simultaneously. A power adapter should be purchased separately.

Charging time: Approximately 3.5 hours for the BP-232WP.

• BC-160 DESKTOP CHARGER + BC-123S AC ADAPTER

For rapid charging of battery packs. A power adapter may be supplied with the charger, depending on the versions.

Charging time: Approximately 3.5 hours for the BP-232WP.

• BC-171 DESKTOP CHARGER + BC-147S AC ADAPTER

A power adapter may be supplied with the charger, depending on the versions.

Charging time: Approximately 11.5 hours for the BP-232WP.

• BC-197 MULTI-CHARGER

For rapid simultaneously charging of up to six battery packs. A power adapter may be supplied with the charger, depending on the version.

Charging time: Approximately 3.5 hours for the BP-232WP.

◇ DC CABLES

• CP-23L CIGARETTE LIGHTER CABLE

Allows charging of the battery pack through a 12 V cigarette lighter socket. (For BC-160/BC-171/BC-119N)

• OPC-515L/OPC-656 DC POWER CABLES

Allows charging of the battery pack using a 13.8 V power source instead of the power adapter.

OPC-515L: For BC-119N/BC-160/BC-171

OPC-656: For BC-121N/BC-197

◇ BELT CLIPS

• MB-93 SWIVEL BELT CLIP

• MB-94/MB-94R BELT CLIP

Exclusive alligator-type belt clip.

• MB-96N/MB-96F LEATHER BELT HANGER

◇ OTHER OPTIONS

- **HM-158LA/HM-159LA/HM-168LWP** SPEAKER-MICROPHONE
Combination speaker-microphone that provides convenient operation while hanging the transceiver on your belt.
- **HM-166LA** EARPHONE-MICROPHONE
Ideal for hands-free operation: clip the HM-166LA (with integrated PTT switch) to your lapel or breast pocket.
Allows you to operate in rainy conditions.
- **FA-SC25V/FA-SC55V/FA-SC25U/
FA-SC57U/FA-SC72U/FA-SC62V/
FA-SC63V/FA-SC03U** ANTENNAS
FA-SC25V: 136–150 MHz FA-SC55V: 150–174 MHz
FA-SC25U: 400–430 MHz FA-SC57U: 430–470 MHz
FA-SC72U: 470–520 MHz FA-SC62V: 150–160 MHz
FA-SC63V: 155–165 MHz FA-SC03U: 380–430 MHz
- **FA-SC56VS/FA-SC57VS/FA-SC73US** STUBBY ANTENNAS
FA-SC56VS: 150–162 MHz FA-SC57VS: 160–174 MHz
FA-SC73US: 450–490 MHz
- **FA-SC61VC/FA-SC61UC** CUT ANTENNAS
FA-SC61VC: 136–174 MHz FA-SC61UC: 380–520 MHz
- **MB-130** VEHICLE CHARGER BRACKET
Mounts the BC-160 DESKTOP CHARGER onto variety of places in a vehicle.

Some options may not be available in some countries. Ask your dealer for details.

Approved Icom optional equipment is designed for optimal performance when used with an Icom transceiver. Icom is not responsible for the destruction or damage to an Icom transceiver in the event the Icom transceiver is used with equipment that is not manufactured or approved by Icom.



Your Icom radio generates RF electromagnetic energy during transmit mode. This radio is designed for and classified as “Occupational Use Only”, meaning it must be used only during the course of employment by individuals aware of the hazards, and the ways to minimize such hazards. This radio is NOT intended for

use by the “General Population” in an uncontrolled environment. This radio has been tested and complies with the FCC and IC RF exposure limits for “Occupational Use Only”. In addition, your Icom radio complies with the following Standards and Guidelines with regard to RF energy and electromagnetic energy levels and evaluation of such levels for exposure to humans:

- FCC OET Bulletin 65 Edition 97-01 Supplement C, Evaluating Compliance with FCC Guidelines for Human Exposure to Radio Frequency Electromagnetic Fields.
- American National Standards Institute (C95.1-1992), IEEE Standard for Safety Levels with Respect to Human Exposure to Radio Frequency Electromagnetic Fields, 3 kHz to 300 GHz.
- American National Standards Institute (C95.3-1992), IEEE Recommended Practice for the Measurement of Potentially Hazardous Electromagnetic Fields— RF and Microwave.
- The following accessories are authorized for use with this product. Use of accessories other than those specified may result in RF exposure levels exceeding the FCC and IC requirements for wireless RF exposure.; Belt Clip (MB-93, MB-94/R and MB-96N/F), Rechargeable Li-ion Battery Pack (BP-232WP) and Speaker-microphone (HM-158LA/HM-159LA/HM-168LWP).



To ensure that your exposure to RF electromagnetic energy is within the FCC and IC allowable limits for occupational use, always adhere to the following guidelines:

- **DO NOT** operate the radio without a proper antenna attached, as this may damage the radio and may also cause you to exceed FCC and IC RF exposure limits. A proper antenna is the antenna supplied with this radio by the manufacturer or antenna specifically authorized by the manufacturer for use with this radio.
- **DO NOT** transmit for more than 50% of total radio use time (“50% duty cycle”). Transmitting more than 50% of the time can cause FCC and IC RF exposure compliance requirements to be exceeded. The radio is transmitting when the TX indicator lights red. You can cause the radio to transmit by pressing the “PTT” switch.
- **ALWAYS keep** the antenna at least 2.5 cm (1 inch) away from the body when transmitting and only use the Icom belt-clips listed on page 23 when attaching the radio to your belt, etc., to ensure FCC and IC RF exposure compliance requirements are not exceeded. To provide the recipients of your transmission the best sound quality, hold the antenna at least 5 cm (2 inches) from your mouth, and slightly off to one side.

The information listed above provides the user with the information needed to make him or her aware of RF exposure, and what to do to assure that this radio operates with the FCC and IC RF exposure limits of this radio.

Electromagnetic Interference/Compatibility

During transmissions, your Icom radio generates RF energy that can possibly cause interference with other devices or systems. To avoid such interference, turn off the radio in areas where signs are posted to do so. **DO NOT** operate the transmitter in areas that are sensitive to electromagnetic radiation such as hospitals, aircraft, and blasting sites.

Occupational/Controlled Use

The radio transmitter is used in situations in which persons are exposed as consequence of their employment provided those persons are fully aware of the potential for exposure and can exercise control over their exposure.



AVERTISSEMENT

Votre radio Icom produit une énergie électromagnétique de radiofréquences (RF), en mode de transmission. Cette radio est conçue pour un «usage professionnel seulement» et classée comme tel, ce qui signifie qu'elle doit être utilisée uniquement dans le cadre d'un travail par des personnes conscientes des dangers et des mesures visant à minimiser ces dangers. Elle N'EST PAS conçue pour une «utilisation grand public», dans un environnement non contrôlé.

Cet appareil a été évalué et jugé conforme, aux limites d'exposition aux RF de la FCC et d'IC, pour une «utilisation grand public». En outre, votre radio Icom satisfait les normes et directives qui suivent en matière de niveaux d'énergie et d'énergie électromagnétique de RF et d'évaluation de tels niveaux en ce qui concerne l'exposition humaine:

Cet appareil a été évalué et jugé conforme, aux limites d'exposition aux RF de la FCC et d'IC, pour une «utilisation grand public». En outre, votre radio Icom satisfait les normes et directives qui suivent en matière de niveaux d'énergie et d'énergie électromagnétique de RF et d'évaluation de tels niveaux en ce qui concerne l'exposition humaine:

- Supplément C, édition 97-01, du Bulletin OET n° 65 de la FCC, «Evaluating Compliance with FCC Guidelines for Human Exposure to Radio Frequency Electromagnetic Fields».
- Norme de l'American National Standards Institute (ANSI): IEEE C95.1-1992 sur les niveaux de sécurité compatibles avec l'exposition humaine aux champs électromagnétiques de radiofréquences (3 kHz à 300 GHz).
- Norme de l'ANSI: IEEE C95.3-1992 sur la méthode d'évaluation recommandée du champ magnétique potentiellement dangereux des radiofréquences et des micro-ondes.
- Les accessoires illustrés à la p. 23-24 sont approuvés pour une utilisation avec ce produit. L'utilisation d'accessoires autres que ceux précisés peut entraîner des niveaux d'exposition aux RF supérieures aux limites établies par la FCC et d'IC en matière d'exposition aux RF sans fil.

Afin de vous assurer que votre exposition à une énergie électromagnétique de RF se situe dans les limites permises par la FCC et d'IC pour une utilisation grand public, veuillez en tout temps respecter les directives suivantes:



MISE EN GARDE

- **NE PAS** faire fonctionner la radio sans qu'une antenne appropriée y soit fixée, car ceci risque d'endommager la radio et causer une exposition supérieure aux limites établies par la FCC et d'IC. L'antenne appropriée est celle qui est fournie avec cette radio par le fabricant ou une antenne spécialement autorisée par le fabricant pour être utilisée avec cette radio.
- **NE PAS** émettre pendant plus de 50 % du temps total d'utilisation de l'appareil («50 % du facteur d'utilisation»). La notion «50% du facteur d'utilisation» s'applique également au mode VOX/PTT. Émettre pendant plus de 50 % du temps total d'utilisation peut causer une exposition aux RF supérieure aux limites établies par la FCC et d'IC. Lorsque le voyant DEL rouge s'allume, cette radio est en train d'émettre. La radio émettra si vous appuyez sur le bouton du microphone.
- **TOUJOURS tenir** l'antenne éloignée d'au moins 2,5 cm de votre corps au moment d'émettre et utiliser uniquement l'attache pour ceinture Icom illustrée à la p. 23, lorsque vous attachez la radio à votre ceinture, ou à autre chose, de façon à vous assurer de ne pas provoquer une exposition aux RF supérieure aux limites fixées par la FCC et d'IC. Pour offrir à vos interlocuteurs la meilleure qualité de transmission possible, tenez l'antenne à au moins 5 cm de votre bouche et légèrement de côté.

Les renseignements ci-dessus fournissent à l'utilisateur toute l'information nécessaire sur l'exposition aux RF et sur ce qu'il faut faire pour assurer que cette radio fonctionne en respectant les limites d'exposition aux RF établies par la FCC et d'IC.

Interférence électromagnétique et compatibilité

En mode de transmission, votre radio Icom produit de l'énergie de RF qui peut provoquer des interférences avec d'autres appareils ou systèmes. Pour éviter de telles interférences, mettez la radio hors tension dans les secteurs où une signalisation l'exige. **NE PAS** faire fonctionner l'émetteur dans des secteurs sensibles au rayonnement électromagnétique tels que les hôpitaux, les aéronefs et les sites de dynamitage.

Usage professionnel/contrôlé

Ce radio émetteur est utilisé dans des cas où des personnes sont exposées en raison de leur travail, pourvu qu'elles soient conscientes du risque d'exposition et qu'elles puissent exercer un contrôle sur cette exposition.

Count on us!

A-7082D-1EX-②
Printed in Japan
© 2013–2015 Icom Inc.

Printed on recycled paper with soy ink.

Icom Inc.

1-1-32 Kamiminami, Hirano-ku, Osaka 547-0003, Japan